

APPLICATION:

PRODUCT NAME:

ATMOSPHERIC VACUUM
BREAKER

JOB NAME:

SPECIAL CONFIGURATION
 CHECK BASE MODEL AND OPTIONS

QUANTITY:

ITEM NO.

MODEL:

3991

OPTIONS OR MODIFICATIONS:

OTHER _____

FEATURES:

- * ATMOSPHERIC VACUUM BREAKER
- * DECK MOUNT

SYSTEM LIMITS

- * TEMP: 40°F MIN. TO 140°F MAX.
- * PRESSURE 200 PSI MAX. STATIC

SHIPPING WEIGHT

* 3.5 LBS

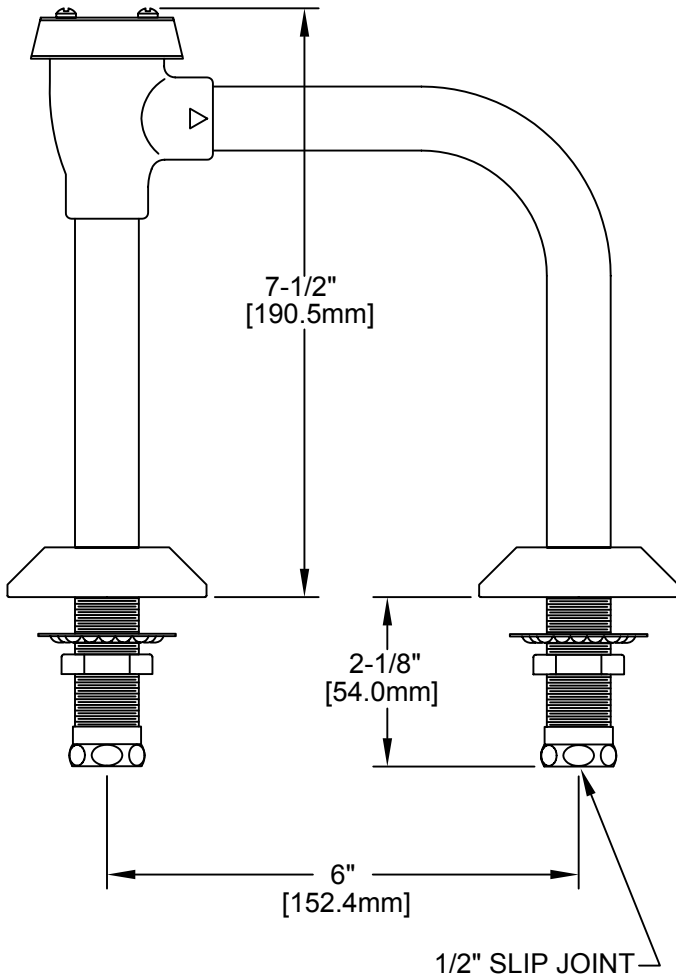

ROUGH-IN:

